

# CAST STEEL BALL VALVE WAFER • DIN PN 40

Материал steel 1.0619; DIN GS-C25

Налягане PN 40

Размер DN 15 - 50

## APPLICATION

Corrosive fluids. Fuel oil, lubricating oil and flammable hydraulic oil. Cargo oil. Air. Gas. Non-flammable hydraulic fluid. Boiler feedwater, condensate. Seawater and freshwater.

## VARIANTS

Other materials on request.

## OPTIONS

Relief hole on ball

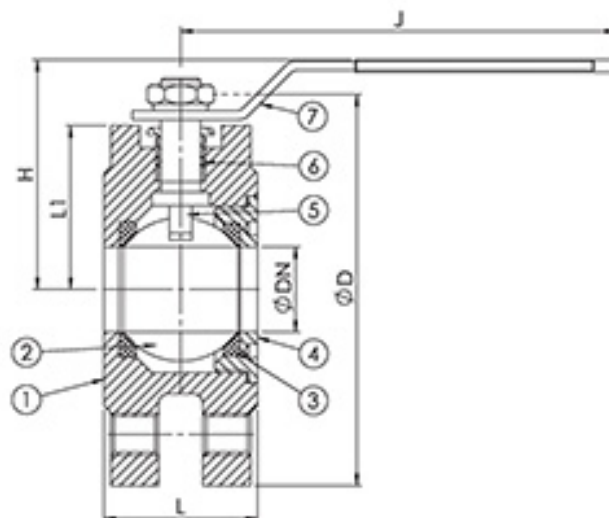

No.	Part	Material	Specifications	
			Standart:	DIN 33571,2 and EN 12516-1
1	Body	Carbon steel 1.0619; DIN GS-C25;	Flange standard:	EN1092-2
2	Ball (relief hole)	Stainless steel 1.4408 (AISI316)	Face to face standard:	EN558, Series 1
3	Seat	PTFE	Execution:	Straight
4	Cap	Stainless steel 1.4408 (AISI316)	Connection type:	Wafer (Between flanges)
5	Stem	Stainless steel 1.4401 (AISI316)	Operation:	Lever
6	Stem packing	PTFE	Actuation:	quarterturn
7	Handle	Stainless steel 1.4401 (AISI316)	Tmax	120 °C

Dn	Pressure rating	Connection	L	D	L1	H	J	Weight (kg)
15	40	40	34,5	95	34	73	150	1,3
20	40	40	38,5	105	39	80,5	150	1,8
25	40	40	44,5	115	45,5	89	155	2,3
32	40	40	54	140	51,3	97,5	173	3,6
40	40	40	62	150	57	104,5	215	4,5
50	40	40	80	165	62	112	215	6,7