

# CAST STEEL BALL VALVE, WELDING ENDS (SW) 3 PARTS • DIN PN 25

Материал steel 1.0619; DIN GS-C25

Налягане PN 25

Размер DN 32 - 50

## APPLICATION

Corrosive fluids. Fuel oil, lubricating oil and flammable hydraulic oil. Cargo oil. Air. Gas. Non-flammable hydraulic fluid. Boiler feedwater, condensate. Seawater and freshwater.

## VARIANTS

Other materials on request.

## OPTIONS

Butt weld connection

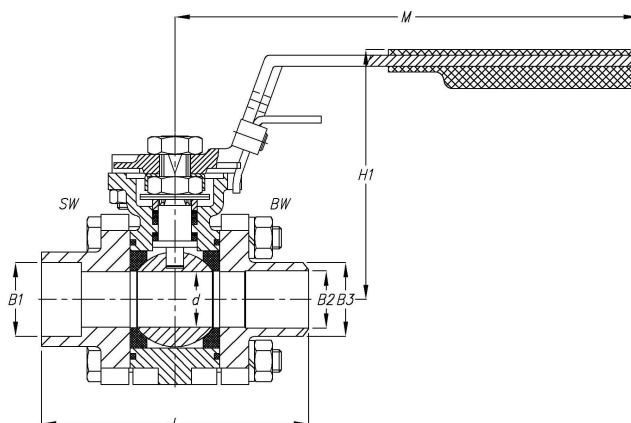

Part	Material	Specifications	
Body	Carbon steel 1.0619; DIN GS-C25;	Standart:	DIN 3202 F1
Cap	Carbon steel 1.0619; DIN GS-C25;	Flange standard:	EN1092-2
Ball	Stainless steel 1.4408 (AISI316)	Face to face standard:	EN558, Series 1
Seat	PTFE	Execution:	Straight
Stem	Stainless steel 1.4408 (AISI316)	Connection type:	Socket Weld DIN3239-2
		Operation:	Lever
		Actuation:	quterturn
		Tmax	120 °C

Dn	D	H	F	H1	L	Butt weld red. port		Butt weld full port		Socket weld w		M	Weight
						B3 [mm]	B2 [mm]	B3 [mm]	B2 [mm]	Red.bore / b1 [mm]	Full bore / b1 [mm]		
	[mm]												
32	31,8	61	22	110	118	48,3	40,9	42,2	35,1	49	43	205	3,2
40	38,1	65	22	115	130	60,3	52,5	48,3	40,9	61,1	49	205	4,2
50	50,8	80	25	130	142	76,1	68,9	60,3	52,5	77,1	61,1	205	6,3