

F7303"

Материал Material:

Налягане Pressure:

Размер Size:

APPLICATIONS

Applications include cooling water systems and steam systems.

VARIANTS AND ADVANTAGES

Spring for SDNR

Body pattern - Straight / Angle

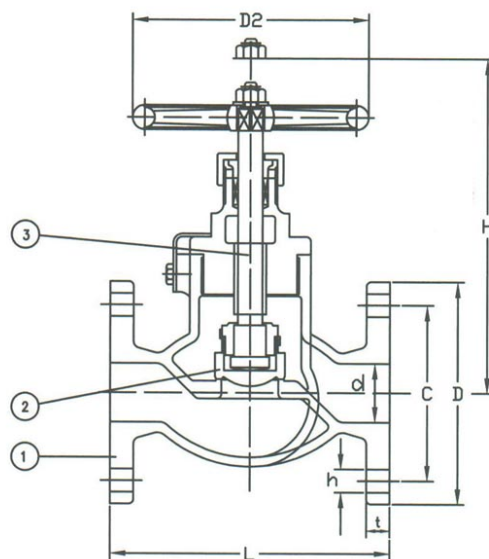

| No. | Parts | Material |
|-----|---------------|------------------|
| 1 | Body / Bonnet | Bronze CC491K |
| 2 | Seat | Bronze CC491K |
| 3 | Disc | Bronze CC491K |
| | Stem | Brass |
| | Handwheel | Cast iron (GG25) |
| | Stem seal | Gland seal |

Specifications

| | |
|------------------------|-------------------------|
| Standart: | JIS |
| Flange standard: | JIS B2220 16K |
| Face to face standard: | JIS B2002 |
| Bonnet connection: | Screwed |
| Execution: | Straight |
| Connection type: | Flanged |
| Operation: | Handwheel / Rising stem |
| Actuation: | Multiturn |
| Tmax at 5 Bars | 205 °C |
| Tmax at 7 Bars | 120 °C |

F7303"

Материал Material:

Налягане Pressure:

Размер Size:

| Dn | Pressure rating | Connection | L | D | C | N x øh | H (open) | D2 | Weight (kg) |
|----|-----------------|------------|-----|-----|-----|--------|----------|-----|-------------|
| 15 | 16 K | 16 K | 110 | 95 | 70 | 4 x 15 | 130 | 80 | 2.76 |
| 20 | 16 K | 16 K | 120 | 100 | 75 | 4 x 15 | 140 | 100 | 3.72 |
| 25 | 16 K | 16 K | 130 | 125 | 90 | 4 x 19 | 160 | 125 | 5.2 |
| 32 | 16 K | 16 K | 160 | 135 | 100 | 4 x 19 | 170 | 125 | 6.91 |
| 40 | 16 K | 16 K | 180 | 140 | 105 | 4 x 19 | 190 | 140 | 8.43 |
| 50 | 16 K | 16 K | 220 | 155 | 120 | N/A | 235 | 140 | N/A |
| 65 | 16 K | 16 K | 270 | 175 | 140 | N/A | 260 | 160 | N/A |