

F7304"

Материал Material:

Налягане Pressure:

Размер Size:

**APPLICATIONS**

Applications include cooling water systems and steam systems.

**VARIANTS AND ADVANTAGES**

Spring for SDNR

Body pattern - Straight / Angle

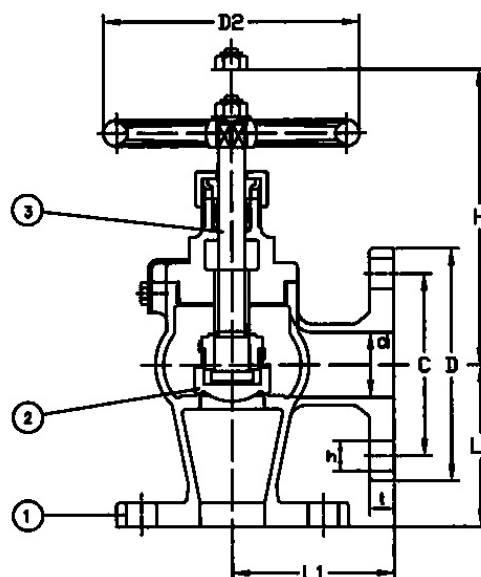

No.	Parts	Material
1	Body / Bonnet	Bronze CC491K
2	Seat	Bronze CC491K
3	Disc	Bronze CC491K
	Stem	Brass
	Handwheel	Cast iron (GG25)
	Stem seal	Gland seal

**Specifications**

Standart:	JIS
Flange standard:	JIS B2220 16K
Face to face standard:	JIS B2002
Bonnet connection:	Screwed
Execution:	Angle
Connection type:	Flanged
Operation:	Handwheel / Rising stem
Actuation:	Multiturn
Tmax at 5 Bars	205 °C
Tmax at 7 Bars	120 °C

F7304"

Материал Material:

Налягане Pressure:

Размер Size:

Dn	Pressure rating	Connection	L1	D	C	N x øh	H (open)	D2	Weight (kg)
15	16 K	16 K	70	95	70	4 x 15	130	80	2.73
20	16 K	16 K	75	100	75	4 x 15	140	100	3.65
25	16 K	16 K	85	125	90	4 x 19	160	125	5.16
32	16 K	16 K	95	135	100	4 x 19	170	125	6.72
40	16 K	16 K	100	140	105	4 x 19	190	140	8.13