

F7307

Материал GLOBE VALVE CAST IRON  
STRAIGHT JIS 7309 16K

Налягане cast iron EN-JL1040; DIN GG25

Размер 16 K

**APPLICATIONS**

Applications include cooling water systems and low pressure steam systems.

**VARIANTS AND ADVANTAGES**

Spring for SDNR  
"Regulating disc, stainless steel trim"

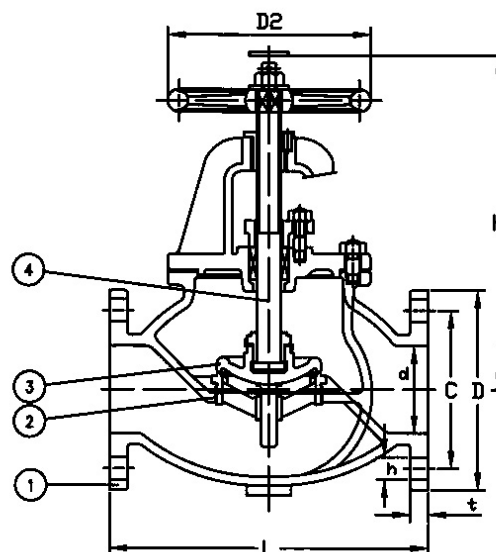

| No. | Parts | Material   |
|-----|-------|--|
| 1   | Body  | Cast iron EN-JL1040 (GG25)                       |
| 2   | Seat  | Bronze BC6                                       |
| 3   | Disc  | Cast iron EN-JL1040 (GG25), Disc ring-Bronze BC6 |
| 4   | Stem  | Brass  |

| Specifications         |               |
|------------------------|---------------|
| Standart:              | JIS F7400     |
| Flange standard:       | JIS B2239 16K |
| Face to face standard: | JIS F7425     |
| Bonnet connection:     | Bolted        |
| Execution:             | Straight      |
| Connection type:       | Flanged       |
| Operation:             | Handwheel     |
| Actuation:             | Multiturn     |
| Tmax at 25 Bars        | 120 °C        |
| Tmax at 16 Bars        | 205 °C        |

| Dn | Pressure rating | Connection | L | D | C | N x øh | H | D2 | Weight (kg) |
|----|-----------------|------------|---|---|---|--------|---|----|-------------|
|----|-----------------|------------|---|---|---|--------|---|----|-------------|

F7307

Материал GLOBE VALVE CAST IRON  
STRAIGHT JIS 7309 16K

Налягане cast iron EN-JL1040; DIN GG25

Размер 16 K

| Dn  | Pressure rating | Connection | L   | D   | C   | N x øh  | H   | D2  | Weight (kg) |
|-----|-----------------|------------|-----|-----|-----|---------|-----|-----|-------------|
| 50  | 16K             | 16K        | 220 | 155 | 120 | 8 x 19  | 285 | 160 | 19.6        |
| 65  | 16K             | 16K        | 270 | 175 | 140 | 8 x 19  | 310 | 200 | 28.3        |
| 80  | 16K             | 16K        | 300 | 200 | 160 | 8 x 23  | 340 | 224 | 40.4        |
| 100 | 16K             | 16K        | 350 | 225 | 185 | 8 x 23  | 385 | 250 | 56.9        |
| 125 | 16K             | 16K        | 430 | 270 | 225 | 8 x 25  | 455 | 315 | 89.5        |
| 150 | 16K             | 16K        | 500 | 305 | 260 | 12 x 25 | 510 | 355 | 123         |
| 200 | 16K             | 16K        | 570 | 350 | 305 | 12 x 25 | 630 | 450 | 188         |