

F7308

Материал GLOBE VALVE CAST IRON ANGLE
JIS 7310 16K
Налягане cast iron EN-JL1040; DIN GG25
Размер 16 K

APPLICATIONS

Applications include cooling water systems and low pressure steam systems.

VARIANTS AND ADVANTAGES

Spring for SDNR
"Regulating disc, stainless steel trim"

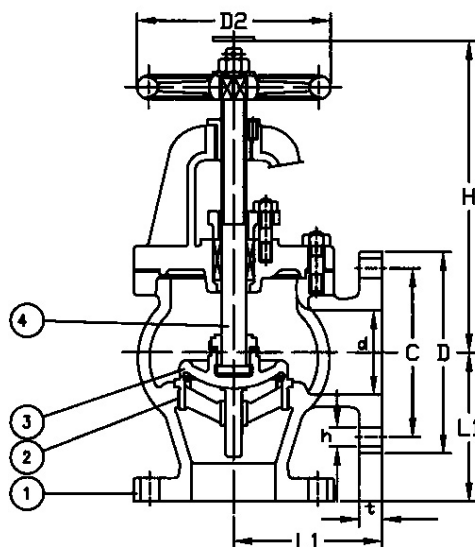

No.	Parts	Material
1	Body	Cast iron EN-JL1040 (GG25)
2	Seat	Bronze BC6
3	Disc	Cast iron EN-JL1040 (GG25), Disc ring-Bronze BC6
4	Stem	Brass

Specifications	
Standart:	JIS F7400
Flange standard:	JIS B2239 16K
Face to face standard:	JIS F7425
Bonnet connection:	Bolted
Execution:	Angle
Connection type:	Flanged
Operation:	Handwheel
Actuation:	Multiturn
Tmax at 22 Bars	120 °C
Tmax at 16 Bars	205 °C

Dn	Pressure rating	Connection	L1	D	C	N x øh	H (open)	D2	Weight (kg)
----	-----------------	------------	----	---	---	--------	----------	----	-------------

F7308

Материал GLOBE VALVE CAST IRON ANGLE
JIS 7310 16K

Налягане cast iron EN-JL1040; DIN GG25

Размер 16 K

Dn	Pressure rating	Connection	L1	D	C	N x øh	H (open)	D2	Weight (kg)
50	16K	16K	120	155	120	8 x 19	255	160	18
65	16K	16K	130	175	140	8 x 19	270	200	25
80	16K	16K	150	200	150	8 x 23	295	224	35.7
100	16K	16K	170	225	175	8 x 23	330	250	49.2
125	16K	16K	200	270	210	8 x 25	390	315	76.1
150	16K	16K	225	305	240	12 x 25	435	355	103
200	16K	16K	250	350	290	12 x 25	540	450	155