

FLOAT STEAM TRAP SCREW ENDS / FLANGED

ADCA FLT 14I DN 25

Материал stainless steel 1.4408

Налягане PN 16

Размер DN 25

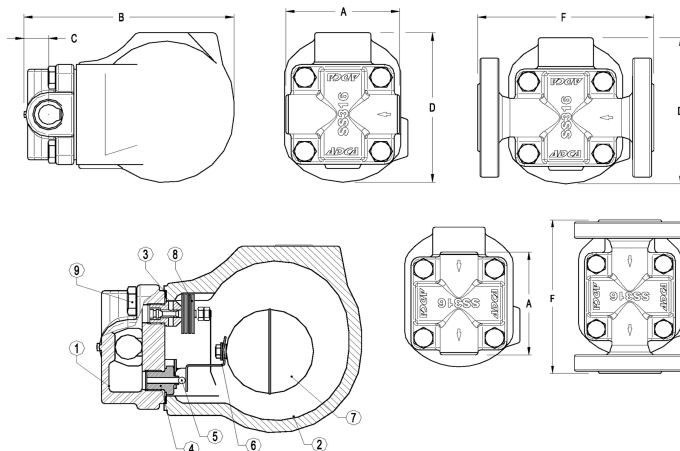

No.	Part	Material
1	Body	CF8M / 1.4408
2	Cover	CF8M / 1.4408
3	Gasket	Stainless st./Graphite
4	Seat	AISI 410 / 1.4006
5	Valve	AISI 440C / 1.4125
6	Lever	AISI 304 / 1.4301
7	Float	AISI 304 / 1.4301
8	Air vent	Stainless st. (Bimetallic)
9	Bolts	St.Steel A2-70

Specifications	
Building standards:	DIN
Connection:	Flanged DN25 / PN16
Bonnet connection:	Bolted
Execution:	Straight
Operation:	Automatic
	With automatic air release
Mounting:	Horizontal / Vertical
Mximum Differentla	4,5 ; 10 ; 14 Bars
Pressure	

FLOAT STEAM TRAP SCREW ENDS / FLANGED
ADCA FLT 14I DN 25

Материал stainless steel 1.4408

Налягане PN 16

Размер DN 25

Dn	A	B	C	D	F	Weight (kg)
DN25	95	178	23	128	160	7,7