

GATE VALVE FORGED FLANGED WITH RISING STEM SW / 150 LBS

Материал steel 1.0619; ASTM A 105 N
 Налягане 150 Lbs
 Размер DN 15 - 50

DESCRIPTIONS

Gate valve used as shut off in cooling, sea water and shipside applications, multiturn operation, non-rising stem.

MEDIA

Steam. Thermal oil. Fuel oil, lubricating oil and flammable hydraulic oil. Cargo oil. Air. Gas. Non-flammable hydraulic fluid. Boiler feedwater, condensate. Seawater and freshwater.

OPTIONS

Larger Dimension on request

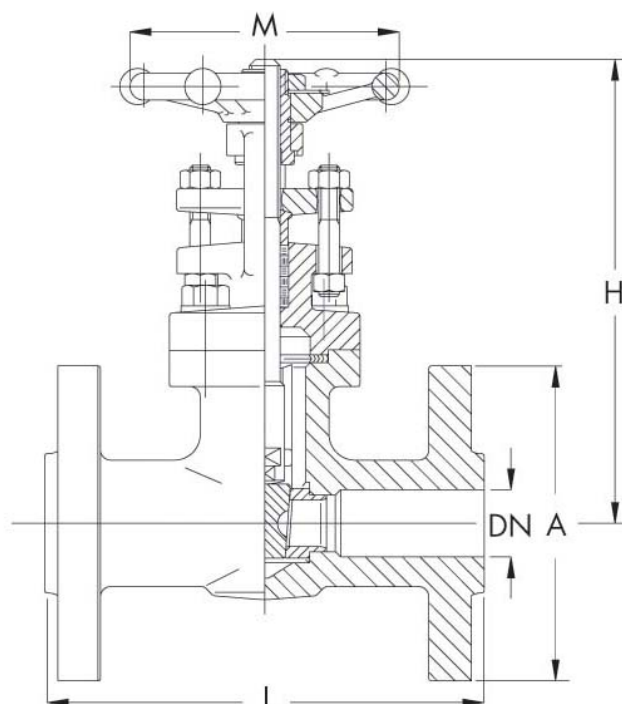

No.	Parts	Material
1	Body	forged Steel ASTM A105N
2	Bonnet	forged Steel ASTM A105N
3	Wedge	ASTM A479 410
4	Seat	ASTM A 479 410 + Stellite
5	Stem	ASTM A479 410
6	Bonnet gasket	St. steel 304 SW + Graphite
7	Gland packing	graphite packing
8	Handwheel	steel

Specifications	
Building standard:	API602 / ISO 15761
Face to Face:	ASME B16.10,T1, Series 7
Trim:	Trim #8
Bonnet connection:	Bolted
Execution:	straight
Connection type:	flanged 150 lbs

GATE VALVE FORGED FLANGED WITH RISING STEM SW / 150 LBS

Материал steel 1.0619; ASTM A 105 N

Налягане 150 Lbs

Размер DN 15 - 50

Specifications	
Operation:	handwheel
Actuation:	multiturn
T max.	400 °C

Dn	Pn	Connection	L	H (open)	P	N x Ø bolts	M	Weight (kg)
Inch	LBS							
1/2"	150 lbs	Flanged	108	178	2 3/8"	4 x 5/8"	102	2.9
3/4"	150 lbs	Flanged	118	179	2 3/4"	4 x 5/8"	102	4.1
1"	150 lbs	Flanged	127	195	3 1/8"	4 x 5/8"	102	4.4
1 1/2"	150 lbs	Flanged	165	232	3 7/8"	4 x 5/8"	140	8.3
2"	150 lbs	Flanged	178	281	4 3/4"	4 x 3/4"	168	15.2

Size P - bolt circle diameter / n x Ø Bolts - number and diameter of bolt holes (inches)