

GATE VALVE NON-RISING STEM F4 DIN

Материал steel 1.0619; DIN GS-C25

Налягане PN 10-16

Размер DN 40 - 600

DESCRIPTIONS

Gate valve used as shut off in cooling, sea water and shipside applications, multiturn operation, non-rising stem.

MEDIA

Steam. Thermal oil. Fuel oil, lubricating oil and flammable hydraulic oil. Cargo oil. Air. Gas. Non-flammable hydraulic fluid. Boiler feedwater, condensate. Seawater and freshwater.

OPTIONS

Larger Dimension on request

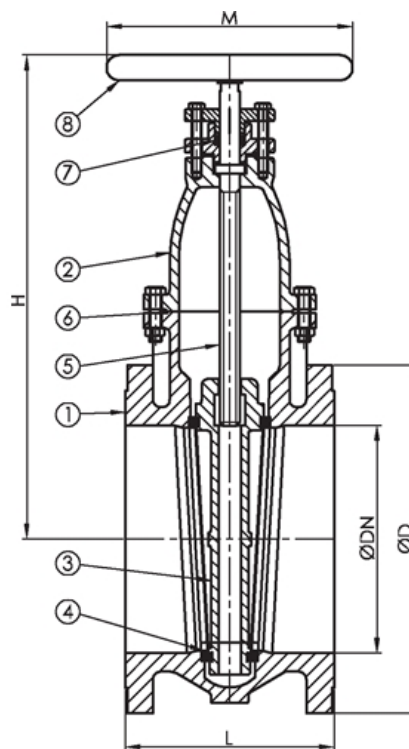

No.	Parts	Materials	Specification	
1	Body	Forged Steel ASTM A105N	Connection	EN 1092-1
2	Bonnet	Forged Steel ASTM A105N	Building length	EN 558, серия 14
3	Gate	ASTM A479 410	Bonnet connection	bolted
4	Seat	ASTM A 479 410 + Stellite	Execution	straight
5	Stem	ASTM A479 410	Connection	flanged
6	Bonnet	st. steel 304 графитен пълнеж	Operation	handwheel
7	Gland packing	графит	Actuation	multiturn
8	Handwheel	Steel	T max. °C	350 °C

Dn	Pressure Rating	Connection	L	D		P		N x d		H	Weight (kg)
				Pn10	Pn16	Pn10	Pn16	Pn10	Pn16		
40	PN 16	PN16	140	150	150	110	110	4x18	4x18	230	15.0
50	PN 16	PN16	150	165	165	125	125	4x18	4x18	235	17.0
65	PN 16	PN16	170	185	185	145	145	4x18	4x18	260	20.0
80	PN 16	PN16	180	200	200	160	160	8x18	8x18	285	27.0
100	PN 16	PN16	190	220	220	180	180	8x18	8x18		34.0

GATE VALVE NON-RISING STEM F4 DIN

Материал steel 1.0619; DIN GS-C25

Налягане PN 10-16

Размер DN 40 - 600

Dn	Pressure	Connection	L	D		P		N x d		H	Weight (kg)
	Rating			Pn10	Pn16	Pn10	Pn16	Pn10	Pn16		
125	PN 16	PN16	200	250	250	210	210	8x18	8x18		50.0
150	PN 16	PN16	210	285	285	240	240	8x23	8x23		60.0
200	PN 10	PN16	230	340	340	295	295	12x23	12x23		100.0
250	PN 10	PN10/16	250	395	405	350	355	12x23	12x26		165.0
300	PN 10	PN10/16	270	445	460	400	410	12x23	12x30		220.0
350	PN 10	PN10/16	290	505	520	460	470	16x26	16x30		250
400	PN 10	PN10/16	310	565	580	515	525	16x26	16x30		292
500	PN 10	PN10/16	350	670	715	620	650	20x26	20x33		380
600	PN 10	PN10/16	390	780	840	725	770	20x30	20x36		490