

GATE VALVE NON-RISING STEM F4 DIN EN 1171 (DIN 3352 T2)

Материал cast iron EN-JL1040

Налягане PN-25-16

Размер DN-40-700

DESCRIPTIONS

Gate valves are stop valves and are widely used in industry and shipbuilding.

They are mainly used in systems that transport water or other liquid fluids, including fuels and toxic products, seawater and hydraulic oils.

MEDIA

Water, fuels, lubricating and hydraulic oils, sea water and other.

OPTIONS

- With position indicator
- Without position indicator
- Different materials of the internal parts (trim)

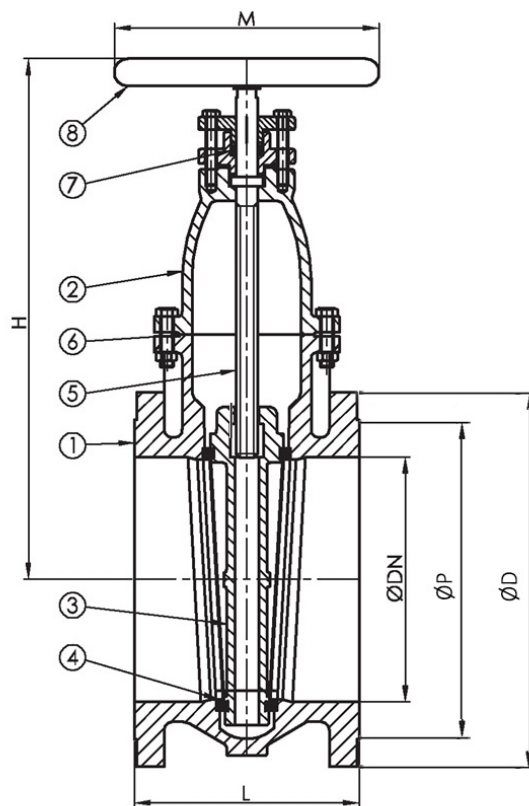

n x d (number of bolt holes X hole diameter)

No.	Parts	Materials
1	Body	cast iron EN-JL1040 (GG25)
2	Bonnet	cast iron EN-JL1040 (GG25)
3	Gate	cast iron EN-JL1040 (GG25)
4	Seat	st.steel 1.4301 (AISI304)
5	Stem	st.steel 1.4021 (AISI420)
6	Bonnet gasket	EPDM aramid
7	Gland packing	teflon/PTFE
8	Handwheel	cast iron EN-JL1040 (GG25)

Specification	
Standard	F4 DIN EN 1171 (DIN 3352 T2)
Connection	EN 1092-2
Building length	EN 558, series 14

GATE VALVE NON-RISING STEM F4 DIN EN 1171 (DIN 3352 T2)

Материал cast iron EN-JL1040

Налягане PN-25-16

Размер DN-40-700

Specification		
Bonnet connection	bolted	
Execution	straight	
Connection	flanged	
Operation	manual	
Actuation	multiturn	
Max working pressure (BAR) AT °C		
DN	Connection	120°C
40 - 150	PN 10	10 Bars
200 - 300	PN 10	6 Bars

Dn	Pn	Flange/pn	H	L	ød			øp*			N x d			ø m	(kg)
					Pn6	Pn10	Pn16	Pn6	Pn10	Pn16	Pn6	Pn10	Pn16		
40	10	6/10/16	255	140	130	150	150	100	110	110	4x14	4x18	4x18	125	10
50	10	6/10/16	270	150	140	165	165	110	125	125	4x14	4x18	4x18	150	12
65	10	6/10/16	323	170	160	185	185	130	145	145	4x14	4x18	4x18	175	17
80	10	6/10/16	355	180	190	200	200	150	160	160	4x18	8x18	8x18	175	22
100	10	6/10/16	405	190	210	220	220	170	180	180	4x18	8x18	8x18	200	27
125	10	6/10/16	460	200	240	250	250	200	210	210	8x18	8x18	8x18	200	33
150	10	6/10/16	518	210	265	285	285	225	240	240	8x18	8x22	8x22	225	43
200	6	6/10/16	608	230	320	340	340	280	295	295	8x18	8x22	12x22	225	65
250	6	6/10/16	708	250	375	395	405	335	350	355	12x18	12x22	12x26	250	100
300	6	6/10/16	818	270	440	445	460	395	400	410	12x22	12x22	12x26	300	142
350	4	10	997	290		505			460			16x22		400	207
400	4	10	1087	310		565			515			16x26		400	246
500	4	10	1308	350		670			620			20x26		500	416
600	2.5	10	1493	390		780			725			20x30		500	624
700	2.5	10	1780	430		895			840			24x30		600	870

Remark: dimensions in column øP, are indicating bolt circle diameter of the connection flanges.