

# GATE VALVE NON-RISING STEM JIS 10K

Материал cast iron EN-JL1040

Налягане 10 К

Размер DN 50 - 300

## DESCRIPTION

Cast iron and cast steel JIS 7400 gate valves with pressure rating acc. to 10K have a flange connection acc. to JIS 10K, inside screwed stem and non-rising handwheel.

## MEDIA

Applications include cooling water systems and low pressure steam systems.

## OPTIONS

- Position indicator
- Body material - Cast steel 1.0619 / A234 WPB

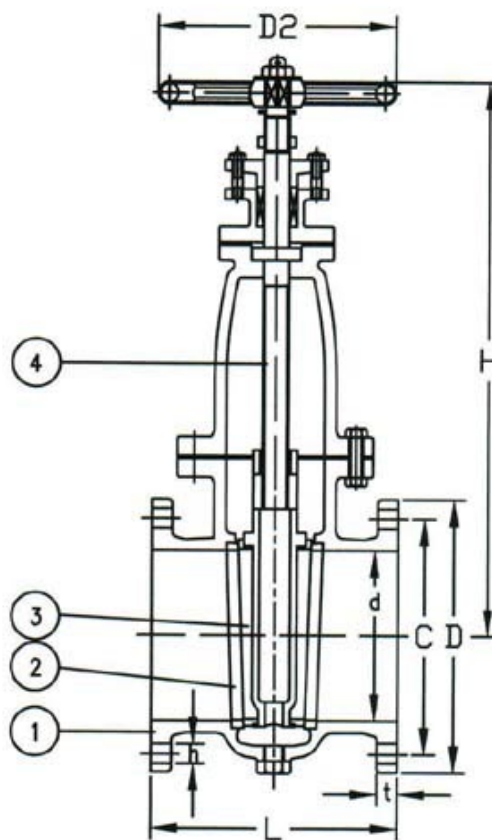

No.	Parts	Material
1	Body	Cast Iron EN-GJL200 (GG20, FC200)
2	Seat	CuSn5Zn5Pb5-C, RG5, CAC406, BC6 (leaded gunmetal bronze)
3	Wedge	Cast Iron EN-GJL200 (GG20, FC200)
4	Stem	CuZn40Pb2, Ms58, C3771BD

Specifications	
Standart:	JIS F7400
Flange standard:	JIS B2239 10K
Face to face standard:	JIS F7425 (JIS F7363)
Bonnet connection:	Bolted

# GATE VALVE NON-RISING STEM JIS 10K

Материал cast iron EN-JL1040

Налягане 10 K

Размер DN 50 - 300

Specifications	
Execution:	Straight
Connection type:	Flanged
Operation:	Handwheel
Actuation:	Multiturn
Tmax at 7 Bars	120 °C
Tmax at 5 Bars	205 °C

Dn	Pn	Connection	L	D	C	N x ød	H	D2	Weight (kg)
50	10K	10K	200	155	120	4x19	270	140	19
65	10K	10K	220	175	140	4x19	295	160	28
80	10K	10K	230	185	150	8x19	325	160	33
100	10K	10K	250	210	175	8x19	360	200	46
125	10K	10K	270	250	210	8x23	450	200	66
150	10K	10K	290	280	240	8x23	500	200	86
200	10K	10K	320	330	290	12x23	560	200	136
250	10K	10K	380	400	355	12x25	620	250	230
300	10K	10K	440	445	400	16x25	730	315	331