

# GATE VALVE NON-RISING STEM JIS 16K

Материал cast iron EN-JL1040

Налягане 16 K

Размер DN 50 - 300

## DESCRIPTION

Cast iron and cast steel JIS 7400 gate valves with pressure rating acc. to 16K have a flange connection acc. to JIS 16K, inside screwed stem and non-rising handwheel.

## MEDIA

Applications include cooling water systems and low pressure steam systems.

## OPTIONS

- Position indicator
- Body material - Cast steel 1.0619 / A234 WPB

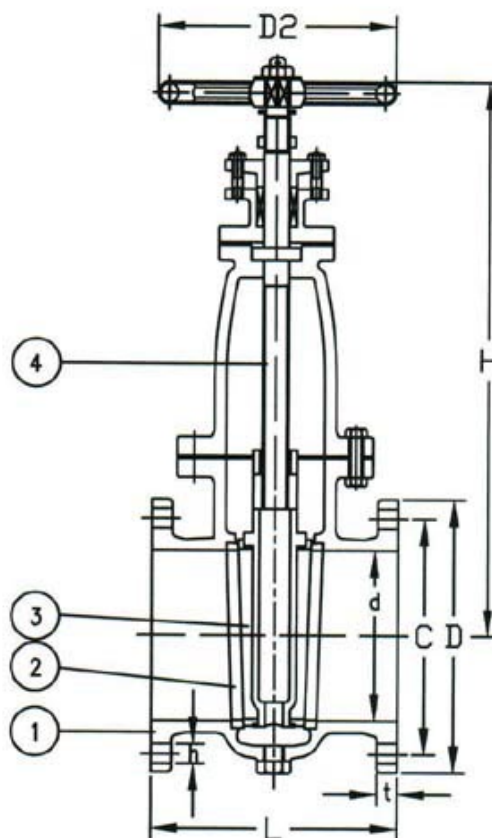

No.	Parts	Material
1	Body	Cast Iron EN-GJL200 (GG20, FC200)
2	Seat	CuSn5Zn5Pb5-C, RG5, CAC406, BC6 (leaded gunmetal bronze)
3	Wedge	Cast Iron EN-GJL200 (GG20, FC200)
4	Stem	CuZn40Pb2, Ms58, C3771BD

## Specifications

Standart:	JIS F7400
Flange standard:	JIS B2239 16K
Face to face standard:	JIS F7425 (JIS F7363)
Bonnet connection:	Bolted
Execution:	Straight
Connection type:	Flanged

# GATE VALVE NON-RISING STEM JIS 16K

Материал cast iron EN-JL1040

Налягане 16 K

Размер DN 50 - 300

Specifications	
Operation:	Handwheel
Actuation:	Multiturn
Tmax at 7 Bars	120 °C
Tmax at 5 Bars	205 °C

Dn	Pn	Connection	L	D	C	N x d	H	D2	Weight (kg)
50	16K	16K	210	155	120	4x19	300	140	19.5
65	16K	16K	240	175	140	4x19	350	160	28
80	16K	16K	260	185	150	8x19	400	180	35
100	16K	16K	290	210	175	8x19	450	200	50
125	16K	16K	310	250	210	8x23	520	250	70
150	16K	16K	330	280	240	8x23	580	280	100
200	16K	16K	370	330	290	12x23	700	355	150
250	16K	16K	430	400	355	12x25	845	450	250
300	16K	16K	490	445	400	16x25	1010	500	423