

GATE VALVE RISING STEM F4 DIN

Материал steel 1.0619; DIN GS-C25

Налягане PN-4-16

Размер DN-40-700

DESCRIPTIONS

Gate valve used as shut off in cooling, sea water and shipside applications, multiturn operation, non-rising stem.

MEDIA

Steam. Thermal oil. Fuel oil, lubricating oil and flammable hydraulic oil. Cargo oil. Air. Gas. Non-flammable hydraulic fluid. Boiler feedwater, condensate. Seawater and freshwater.

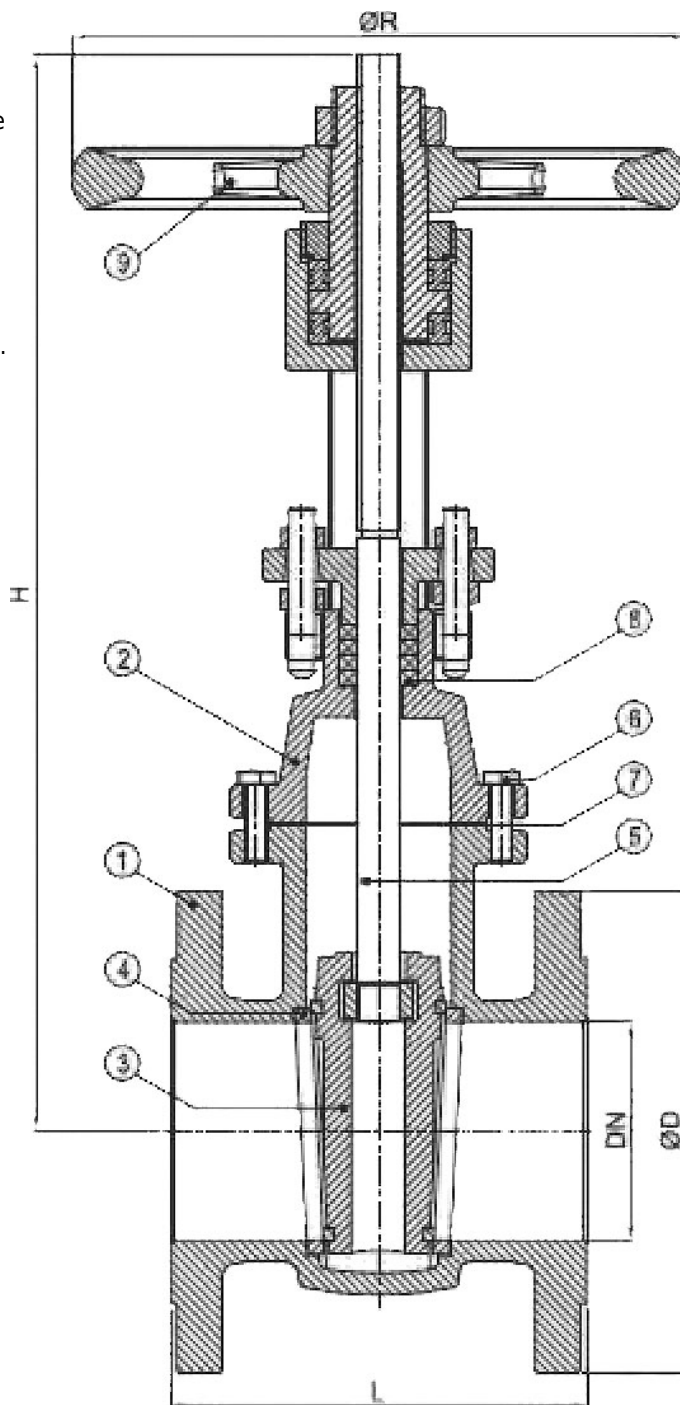

GATE VALVE RISING STEM F4 DIN

Материал steel 1.0619; DIN GS-C25

Налягане PN-4-16

Размер DN-40-700

No.	Parts	Materials	Specification	
1	Body	steel GP240GH 1.0619 GSC25	Building standard	DIN 3352 T3
2	Bonnet	steel GP240GH 1.0619 GSC25	Connection	flanged acc.DIN to EN 1092-1/B (DIN 2501)
3	Gate	steel GP240GH 1.0619 GSC25	Building lenght	EN 558 серия 14 (DIN 3202 F4)
4	Seat	st. steel X5CrNi18-10 (1.4301)	Bonnet connection	bolted
5	Stem	X20Cr13 (1.4021)	Execution	straight
6	Bonnet gasket	Asbestoss free gasket	Connection	flanged
7	Gland packing	teflon/PTFE	Operation	handwheel
8	Handwheel	Cast Iron EN-GJL250, EN-JL 1040	Actuation	multiturn
			T max. °C	350 °C

Dn	Pn	Connection	L	D		P		N x d		H	R	Weight (kg)
				Pn10	Pn16	Pn10	Pn16	Pn10	Pn16			
40	PN 16	PN16	140	150		110		4x18		230	140	15.0
50	PN 16	PN16	150	165		125		4x18		235	140	17.0
65	PN 16	PN16	170	185		145		4x18		260	160	20.0
80	PN 16	PN16	180	200		160		8x18		285	160	27.0
100	PN 16	PN16	190	220		180		8x18		320	200	34.0
125	PN 16	PN16	200	250		210		8x18		395	200	50.0
150	PN 16	PN16	210	285		240		8x23		435	200	60.0
200	PN 10	PN16	230	340		295		12x23		555	250	100.0
250	PN 10	PN10/16	250	395	405	350	355	12x23	12x26	645	315	165.0
300	PN 10	PN10/16	270	445	460	400	410	12x23	12x30	1160	500	220.0
350	PN 6	PN10/16	290	505	520	460	470	16x26	16x30	1305	500	250
400	PN 6	PN10/16	310	565	580	515	525	16x26	16x30	1405	640	292
500	PN 6	PN10/16	350	670	715	620	650	20x26	20x33	1785	720	530
600	PN 4	PN10/16	390	780	840	725	770	20x30	20x36	1935	720	640
700	PN 4	PN10/16	430	895	910	840	840	24 x 30	24x36	2200	800	830