

# GLOBE VALVE TYPE 01301 01301 SOLDERED COPPER ENDS

Материал bronze CC491K

Налягане PN 50

Размер DN 10 - 50

## DESCRIPTION

CRYOGENE GLOBE VALVE TYPE 01301 WITH BRAZED COPPER STUBS, PN 50

- Top part - flanged connection
- Body and top part - bronze
- " live loaded " gland packing
- " cleaned and degreased for oxygen service "
- Part No. №01301X0008
- Part No. № 01301.X.5008 Globe/Check Valve
- Inlet and outlet with brazed copper stubs

Approved for air gases, vapours and cryogenic liquefied gases incl. LNG.

- Working temp. [°C]: -196°C / -321°F (77K) до +120°C / +248°F (393K)
- Recommended working temp. [°C]: -60°C / -76°F (213K) до +120°C / +248°F (393K)

## VARIANTS

Available options - on request only:

- Welded stainless steel stubs acc. to ISO 1127
- Valve with control disc (tapered design)

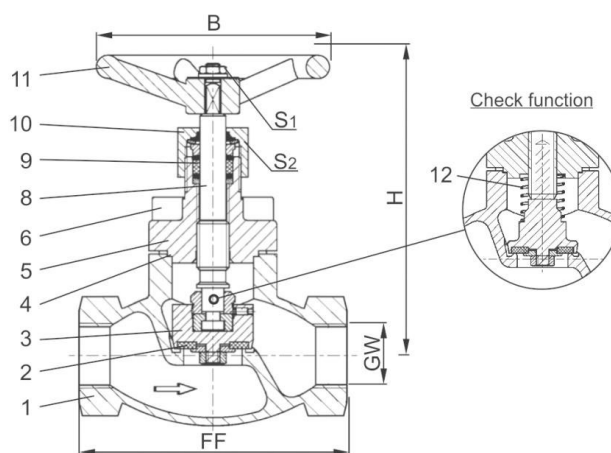

No.	Parts	Materials
1	Body	bronze CC491K
2	Sealing	PTFE / Elektrocarbon (25%)
3	Valve	brass CW612N
4	Cover sealing	PTFE / Folie
5	Cover	bronze CC493K
6	Cover connection	stainless steel 1.4301/A2
8	Stem	1.4301/A 276 Grade 304
9	Gland packing	graphite/PTFE
10	Gland cover	brass CW612N
11	Wheel	Al- alloy
12	Spring	B 103 UNS C51900
13	Brazed copper stubs	copper B 152 UNS C12200

# GLOBE VALVE TYPE 01301 01301 SOLDERED COPPER ENDS

Материал bronze CC491K

Налягане PN 50

Размер DN 10 - 50

Specifications	
Type:	01301 - globe valve
Connection standard:	DIN EN 12449 or ASTM B88
Face to face lenght:	JIS F7425 (JIS F7363)
Cover connection:	Bolted
Body type:	Straight
Connection ends:	brazed copper stubs acc. to DIN EN 12449
Actuation:	Multiturn
Working temp. [°C]	'-196 °C to 120 °C
Recommended working temp. [°C]	'-60°C to 120 °C

Nominal diameter	Dn	10	15	20	25	32	40	50
Dimension code	X.	1012	1515	2022	2528	3235	4042	5054
Face to face dimension	FF	60	85	85	115	115	140	160
Height	H	140	140	140	140	170	175	200
Outside pipe-Ø	RA	12.0	15.0	20.0	25.0	32.0	42.0	54.0
Socket depth	b	6	6	8	8	10	13	20
Handwheel-Ø	B	80	100	100	100	125	125	125
Wrench size across flats	S,	10	10	10	10	13	13	13
Wrench size across flats	S2	30	30	30	30	36	36	36
Weight. kg	1,0	1,3	1,7	2,0	2,8	4,2	6,7	
Kvs-Value	m3/h	1,6	4.3	6,7	11,5	12,1	22,6	37,1
Cv-Value	gal /min	1.9	5,0	7,8	13,4	14,1	26,3	43,2