

MUD-BOX STRAIGHT, FLANGED PN 2.5 - 4

Материал cast iron EN-JL1040; DIN GG25

Налягане PN 25-40

Размер DN 40 - 600

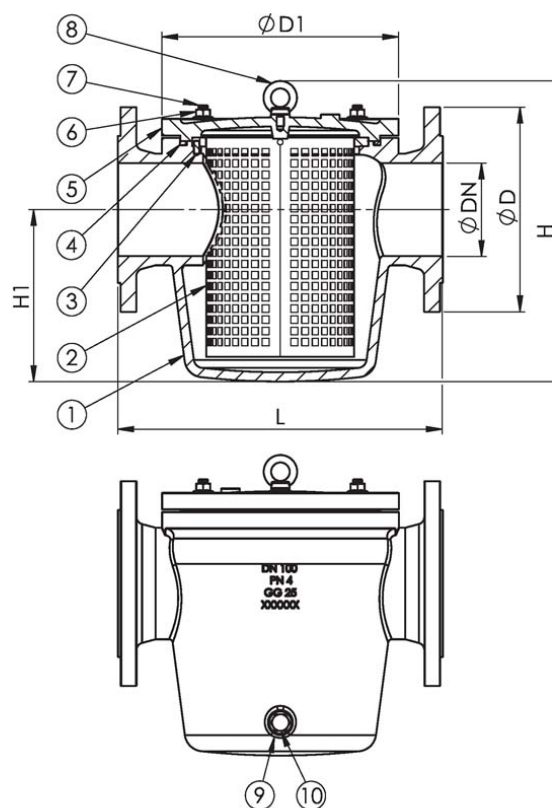

No.	Part	Material
1	Body	Cast iron EN-JL1040 (GG25)
2.1	Strainer DN 40-300	St. steel 1.4432 (AISI316L)
2.2	Strainer DN 350-600	St. steel 1.4401 (AISI316)
3.1	Pin	DN 40-300 St. steel 1.4432 (AISI316L)
3.2	Pin	DN 350-600 St. steel 1.4401 (AISI316)
4	O-ring	NBR
5	Bonnet	Cast iron EN-JL1040 (GG25)
6	Flange nut	8.8 FZB
7	Stud bolt	8.8 FZB
8	Lifting eyebolt	8.8 FZB
9	Washer	DN 80-600 Copper
10	Plug	DN 80-600 Brass CW614N (Ms58)

MUD-BOX STRAIGHT, FLANGED PN 2.5 - 4

Материал cast iron EN-JL1040; DIN GG25

Налягане PN 25-40

Размер DN 40 - 600

Specifications	
Standart:	DIN
Execution:	Straight
Bonnet:	Bolted
Connection type:	Flanged EN1092-1
Face to face:	EN 558, Series 1
Actuation:	No actuation
Tmax	120 °C
Perforation:	DN 40-65 5 x 5 mm
	DN 80-600 8 x 8 mm

Dn	Pn	Connection	L	D	D1	H	H1	Weight (kg)
40	PN 4	PN 10	200	150	130	191	95	10
50	PN 4	PN 10	230	165	160	214	106	14
65	PN 4	PN 10	290	185	197	252	134	21
80	PN 4	PN 10	310	200	215	282	156	25
100	PN 4	PN 10	350	220	255	323	185	37
125	PN 4	PN 10	400	250	293	394	229	51
150	PN 4	PN 10	480	285	340	447	268	68
350	PN 4	PN 10	610	505		740		300
400	PN 4	PN 10	740	565		900		430
450	PN 4	PN 10	1000	615		1000		480
500	PN 2.5	PN 10	1100	670		1100		555
600	PN 2.5	PN 10	1100	780		1100		820