

# SOCKOLET / ASME B.31

Материал steel A105

Налягане 63 Bar

Размер 1" - 1 1/2"

## APPLICATIONS

Socketlets are pipe branch weld connections.

## VARIANTS

Other materials: Ferritic and Austenitic steels

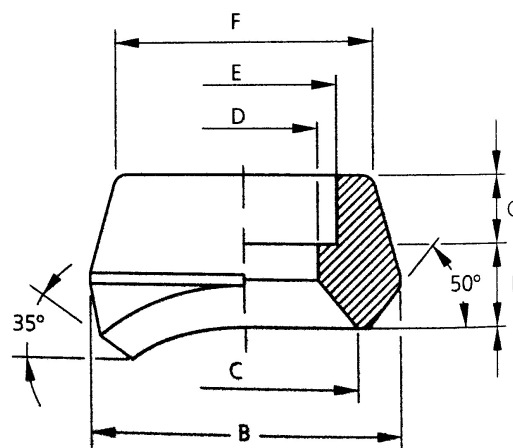

No.	Part	Material
1	Socketlet	Carbon steel A105

Specifications	
Standart:	ASME B.31

Run pipe	Outlet	Sch	B mm	C mm	D mm	E mm	F mm	G mm	I mm
2"	1"	SCH 160	54,0	36,5	26,6	33,8	46,0	13,5	19,8
4" - 5"	1"	SCH 160	54,0	36,5	26,6	33,8	46,0	13,5	19,8
6" - 10"	1"	SCH 160	54,0	36,5	26,6	33,8	46,0	13,5	19,8
3 1/2" - 4"	1 1/2"	SCH 80	73,0	50,8	40,9	48,6	61,9	15,1	19,8