

STEAM TRAP WITH AIR RELEASE SCREW ENDS ADCA TSS 22

Материал stainless steel AISI304 / 1.4301

Налягане PN 40

Размер 1/4" - 1"

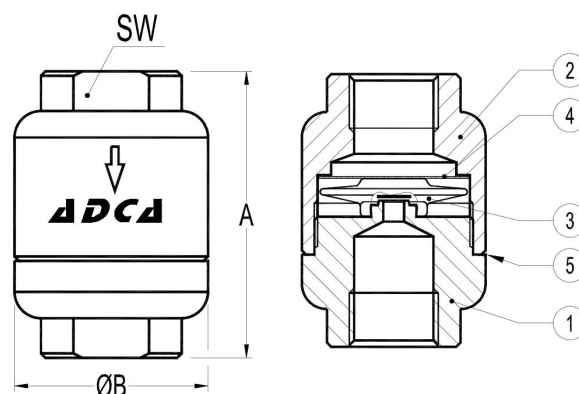

| No. | Part | Material |
|-----|----------------------|--------------------|
| 1 | Body | AISI 304/1.4301 |
| 2 | Cover | AISI 304/1.4301 |
| 4 | Thermostatic element | Stainless steel |
| 5 | Strainer screen | AISI 304/1.4301 |
| 6 | Gasket | St. Steel/Graphite |

| Specifications | |
|---------------------|-------------------------------------|
| Building standards: | DIN |
| Connection: | Threaded BSP |
| Bonnet connection: | Screw |
| Execution: | Straight |
| Operation: | Automatic |
| Air release: | With automatic air release |
| Mounting: | Horizontal or Vertical installation |

| Max. working pressure (bar) at ?c | | | |
|-------------------------------------|--|-----|-------|
| PMO - maximum operating pressure | | 22 | [bar] |
| TMO - maximum operating temperature | | 250 | |

| Body limiting conditions | |
|--------------------------|--------------|
| THREADED PN40 | Related temp |
| Allow. Press. / Bars | 0C |

STEAM TRAP WITH AIR RELEASE SCREW ENDS ADCA TSS 22

Материал stainless steel AISI304 / 1.4301

Налягане PN 40

Размер 1/4" - 1"

| Body limiting conditions | |
|--------------------------|--|
| 34.4 bar | |
| 30.8 Bar | |
| 28 bar | |
| 26 bar | |

| Flow rate capacity in kg/h | | | | | | | | | | | | | | | | |
|----------------------------|-----------|-----------------------------|-----|-----|----|-----|-----|-----|-----|-----|-----|-----|-----|-----|-----|-----|
| MODEL | SIZE DN | DIFFERENTIAL PRESSURE (bar) | | | | | | | | | | | | | | |
| | | 0.2 | 0.3 | 0.5 | 1 | 1.5 | 2 | 3 | 4 | 6 | 8 | 10 | 13 | 15 | 20 | 22 |
| TSS 22 | 1/4" - 1" | 45 | 55 | 70 | 95 | 125 | 135 | 180 | 200 | 270 | 315 | 330 | 360 | 370 | 405 | 415 |

| Dimensions (mm) | | | | |
|-----------------|----|----|----|---------|
| SIZE DN | A | B | SW | WGT. Kg |
| 1/4" | 65 | 44 | 27 | 0.5 |
| 3/8" | 65 | 44 | 27 | 0.5 |
| 1/2" | 65 | 44 | 27 | 0.45 |
| 3/4" | 65 | 44 | 36 | 0.47 |
| 1" | 65 | 44 | 40 | 0.4 |