

STEAM TRAP WITH INVERSE PISTON ADCA IB30S / IB30SS

Материал stainless steel 1.4408 ; cast steel
1.0460
Налягане PN 40
Размер DN 15 - 25

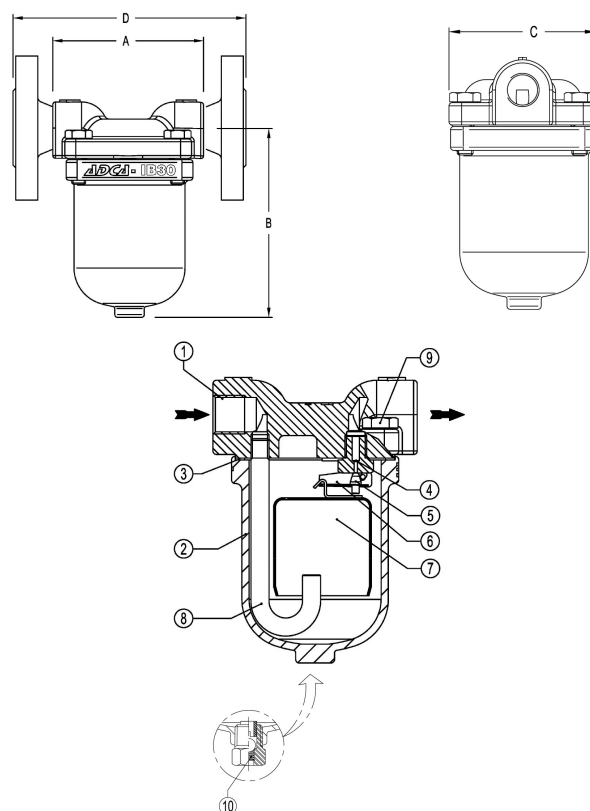

No.	Part	Material ib30s	Material ib 30 ss
1	Body	P250GH/1.0460	CF8M / 1.4408
2	Cover	CF8M / 1.4408	CF8M / 1.4408
4	Gasket	Gasket Graphite Graphite	Gasket Graphite Graphite
5	Seat	Seat AISI 410 / 1.4006	Seat AISI 410 / 1.4006
	Valve	Seat AISI 410 / 1.4006	Seat AISI 410 / 1.4006
	Lever	AISI 304 / 1.4301	AISI 304 / 1.4301
	Bucket	AISI 304 / 1.4301	AISI 304 / 1.4301
	Inlet tube	AISI 304 / 1.4301	AISI 304 / 1.4301
	Bolts	Bolts A2 - 70 A2 - 70	Bolts A2 - 70 A2 - 70
	Anti-freeze device	AISI 304 / 1.4301	AISI 304 / 1.4301

Specifications	
-----------------------	--

STEAM TRAP WITH INVERSE PISTON ADCA IB30S / IB30SS

Материал stainless steel 1.4408 ; cast steel
1.0460
Налягане PN 40
Размер DN 15 - 25

Specifications	
Building standards:	DIN / ANSI
Connection:	Threaded BSP
Bonnet connection:	Screw
Execution:	Straight
Operation:	Automatic
Air release:	With automatic air release
Mounting:	Horizontal

Max. working pressure (bar) at ?c			
PMO - maximum operating pressure		27	[bar]
TMO - maximum operating temperature		380	

Body limiting conditions				
IB30S		IB30SS		Related temp
Flanged PN40 / ANSI 300	Flanged ANSI 150	Flanged PN40/ANSI300	Flanged ANSI150	
Allow. Press. / Bars	Allow. Press. / Bars	Allow. Press. / Bars	Allow. Press. / Bars	
37.1	15.4	40	16	
33.3	13.8	33.7	13.6	
25.7	8.4	28.5	8.4	
23.8	6.5	27.4	6.5	

Flow rate capacity in kg/h												
MODEL	SIZE DN	DIFFERENTIAL PRESSURE (bar)										
		1	2	3	4	5	6	7	8	10	11	12
IB30-4	15-25	280	390	470	530							
IB30-8	15-25	190	260	320	360	400	430	460	500			
IB30-12	15-25	160	220	260	290	320	360	370	400	440	480	490

Body limiting conditions	
THREADED PN40	Related temp

**STEAM TRAP WITH INVERSE PISTON ADCA
IB30S / IB30SS**

Материал stainless steel 1.4408 ; cast steel
1.0460
Налягане PN 40
Размер DN 15 - 25

Body limiting conditions	
Allow. Press. / Bars	0С
34.4 bar	
30.8 Bar	
28 bar	
26 bar	