

STEAM TRAP WITH INVERSE PISTON ADCA IB35S / IB35SS

Материал stainless steel 1.4408 ; cast steel
1.0460
Налягане PN 40
Размер DN 15 - 25

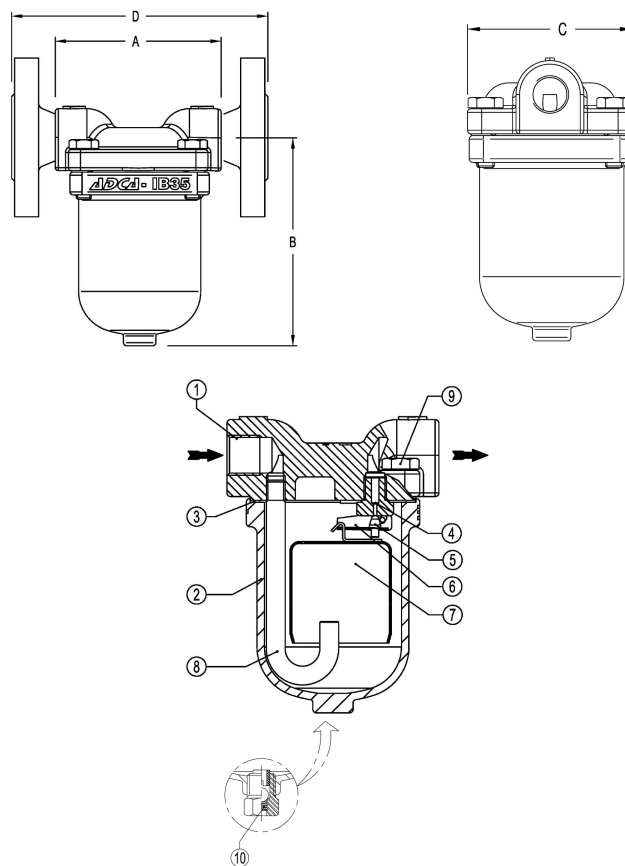

No.	Part	Material ib30s	Material ib 30 ss
1	Body	P250GH/1.0460	CF8M / 1.4408
2	Cover	CF8M / 1.4408	CF8M / 1.4408
4	Gasket	Gasket Graphite Graphite	Gasket Graphite Graphite
5	Seat	Seat AISI 410 / 1.4006	Seat AISI 410 / 1.4006
	Valve	Seat AISI 410 / 1.4006	Seat AISI 410 / 1.4006
	Lever	AISI 304 / 1.4301	AISI 304 / 1.4301
	Bucket	AISI 304 / 1.4301	AISI 304 / 1.4301
	Inlet tube	AISI 304 / 1.4301	AISI 304 / 1.4301
	Bolts	Bolts A2 - 70 A2 - 70	Bolts A2 - 70 A2 - 70
	Anti-freeze device	AISI 304 / 1.4301	AISI 304 / 1.4301

Specifications

STEAM TRAP WITH INVERSE PISTON ADCA IB35S / IB35SS

Материал stainless steel 1.4408 ; cast steel
1.0460
Налягане PN 40
Размер DN 15 - 25

Specifications	
Building standards:	DIN / ANSI
Connection:	Threaded BSP
Bonnet connection:	Screw
Execution:	Straight
Operation:	Automatic
Air release:	With automatic air release
Mounting:	Horizontal

Max. working pressure (bar) at ?c			
PMO - maximum operating pressure		27	[bar]
TMO - maximum operating temperature		380	

Body limiting conditions				
IB35S		IB35SS		Related temp
Flanged PN40 / ANSI 300	Flanged ANSI 150	Flanged PN40/ANSI300	Flanged ANSI150	
Allow. Press. / Bars	Allow. Press. / Bars	Allow. Press. / Bars	Allow. Press. / Bars	
37.1	15.4	40	16	
33.3	13.8	33.7	13.6	
25.7	8.4	28.5	8.4	
23.8	6.5	27.4	6.5	

Flow rate capacity in kg/h	MODEL	SIZE DN	DIFFERENTIAL PRESSURE (bar)																
				1	2	3	4	5	6	7	8	10	11	12	14	17	20	22	24
	IB35-17	15-25	140	180	200	215	225	235	240	250	265	270	275	280	400				
	IB35-27	15-25	80	100	115	120	125	132	137	140	150	153	155	152	233	240	245	250	255

Dimensions (mm) ib35s															

STEAM TRAP WITH INVERSE PISTON ADCA IB35S / IB35SS

Материал stainless steel 1.4408 ; cast steel
1.0460
Налягане PN 40
Размер DN 15 - 25

Dimensions (mm) ib35s										
SCREW ENDS and SW					EN PN16/40		ANSI 150		ANSI 300	
SIZE DN	A	B	C	WGT. Kg	D	WGT. Kg	D	WGT. Kg	D	WGT. Kg
15 - 1/2"	110	125	92	2.3	170	3.8	170	3.3	170	4.1
20 - 3/4"	110	125	92	2.3	170	4.3	170	3.7	170	5.3
25 - 1"	160	125	92	2.3	180	4.9	180	4.5	180	6.5
DIMENSIONS (mm) IB35SS										
SCREW ENDS and SW					EN PN16/40		ANSI 150		ANSI 300	
SIZE DN	A	B	C	WGT. Kg	D	WGT. Kg	D	WGT. Kg	D	WGT. Kg
15 - 1/2"	110	125	92	2.3	170	3.8	170	3.3	170	4.1
20 - 3/4"	110	125	92	2.3	170	4.3	170	3.7	170	5.3
25 - 1"	160**	125	92	2.3	180	4.9	180	4.5	180	6.5