

STEEL CHECK VALVE WAFER TYPE W409 DIN PN 25

Материал steel 1.0619; DIN GS-C25

Налягане PN 25

Размер DN-40-500

DESCRIPTION

Wafer type swing check valve, for installation between flanges PN10/PN25.

MEDIA

- Steam. Thermal oil. Fuel oil, lubricating oil and flammable hydraulic oil. Cargo oil. Air. Gas.
- Non-flammable hydraulic fluid. Boiler feedwater, condensate. Seawater and freshwater.

VARIANTS

O-ring material EPDM (-40°C to +120°C), PTFE (-50°C to +220°C) or FPM/FKM (-30°C to +180°C). Larger dimensions on request.

OPTIONS

Other materials on request

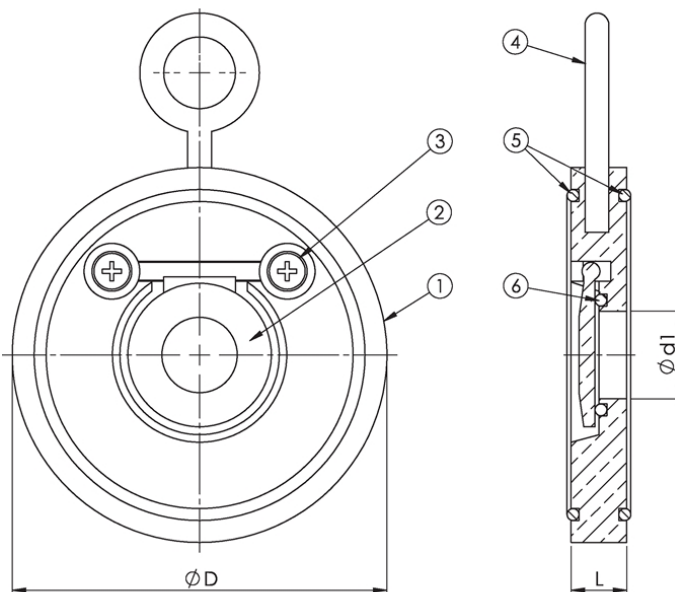

No.	Part	Material	Specifications	
1	Body	Cast steel 1.0619 (WCB) Galvanised	Standart:	DIN, ANSI, JIS
2	Disc	Cast steel 1.0619 (WCB) Galvanised	Flange standard:	Wafer
3	Bolt	Cast steel 1.0619 (WCB) Galvanised	Face to face standard:	As producer specification
4	Eye bolt	8.8 FZB	Connection type:	Wafer
5	O-ring	NBR	Operation:	Non-return valve
6	O-ring	NBR	Actuation:	Self Return
			Tmax	220 °C

Dn	Pressure rating	Connection	L	D1	D	Weight (kg)
40	25	25	14	22	94	0,9
50	25	25	14	32	109	1,2
65	25	25	14	40	129	1,5
80	25	25	14	54	144	2,5
100	25	25	18	70	170	3,5
125	25	25	18	92	196	5

**STEEL CHECK VALVE WAFER TYPE W409 DIN
PN 25**

Материал steel 1.0619; DIN GS-C25

Налягане PN 25

Размер DN-40-500

Dn	Pressure rating	Connection	L	D1	D	Weight (kg)
150	25	25	20	112	226	5,5
200	25	25	22	154	286	8
250	25	25	26	200	343	15
300	25	25	32	240	403	24
350	25	25	38	270	460	39
400	25	25	44	310	520	59
450	25	25	50	360	567	70
500	25	25	56	405	622	90