

STORM VALVE CAST STEEL ANGLE FLANGED DIN PN 10

Материал steel 1.0619; DIN GS-C25; ASTM A216WCB
 Налягане PN 10
 Размер DN-50-150

APPLICATIONS

Discharge of sewage water. For vertical installation.

VARIANTS

Other dimensions on request.

MEDIA

Seawater and freshwater

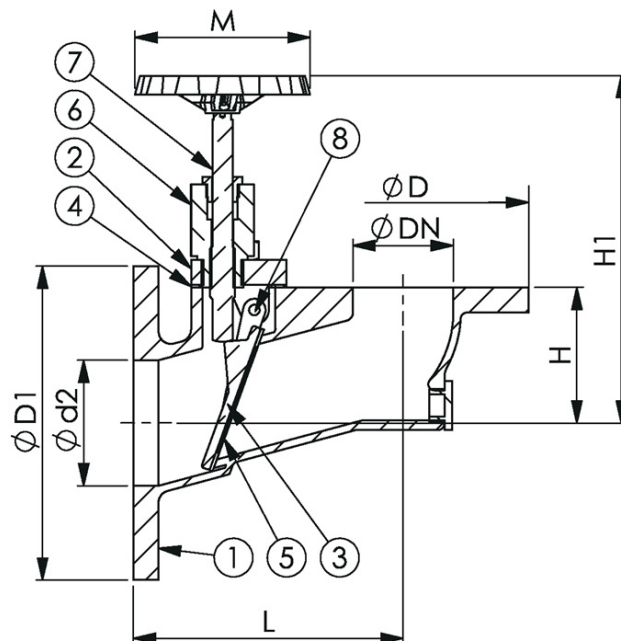

No.	Parts	Material
1	Body	Cast steel 1.0619 (WCB)
2	Bonnet	Cast steel 1.0619 (WCB)
3	Disc	Bronze CC491K (RG5)
4	Gasket	NBR
5	Sealing	NBR
6	Stem nut	Brass CW614N (Ms58)
7	Stem	Brass CW614N (Ms58)
8	Pin	Stainless steel 1.4401 (AISI316)

Specifications

Standart:	DIN
Flange standard:	EN 1092-3
Face to face standard:	EN 558, series 48
Bonnet connection:	Bolted
Execution:	Angle

STORM VALVE CAST STEEL ANGLE FLANGED DIN PN 10

Материал steel 1.0619; DIN GS-C25; ASTM
A216WCB
Налягане PN 10
Размер DN-50-150

Specifications	
Connection type:	Flanged
Operation:	Handwheel
Actuation:	Multiturn
Trange at Pmax 4 Bars:	-10 °C ÷ +60°C

Dn	Pressure rating	Connection	L	D	D1	D2	H	H1	M	Weight (kg)
50	PN 4	PN 10	180	165	200	68	90	260	140	13
65	PN 4	PN 10	200	185	220	85	100	270	140	15
80	PN 4	PN 10	215	200	250	100	108	290	140	21
100	PN 4	PN 10	250	220	285	130	130	305	140	26
125	PN 4	PN 10	290	250	315	158	152	330	160	37
150	PN 4	PN 10	330	285	340	190	176	350	160	45