

# STORM VALVE CAST STEEL STRAIGHT FLANGED DIN PN 10 DIN PN 10

Материал steel 1.0619; DIN GS-C25; ASTM A216WCB  
 Налягане PN 10  
 Размер DN-50-150

### APPLICATIONS

Discharge of sewage water. For vertical installation.

### VARIANTS

Other dimensions on request.

### MEDIA

Seawater and freshwater

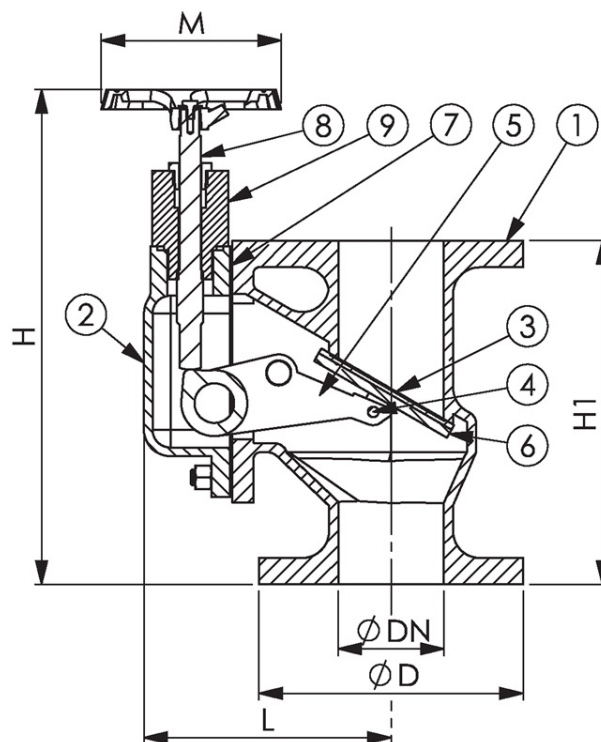

No.	Parts	Material
1	Body	Cast steel 1.0619 (WCB)
2	Bonnet	Cast steel 1.0619 (WCB)
3	Sealing	NBR
4	Pin	Stainless steel 1.4401 (AISI316)
5	Lever	Cast steel 1.0619 (WCB)
6	Disc	Bronze CC491K (RG5)
7	Gasket	NBR
8	Stem	Brass CW614N (Ms58)
9	Stem Nut	Brass CW614N (Ms58)

### Specifications

Standart:	DIN
Flange standard:	EN 1092-3
Face to face standard:	EN 558, series 48

# STORM VALVE CAST STEEL STRAIGHT FLANGED DIN PN 10 DIN PN 10

Материал steel 1.0619; DIN GS-C25; ASTM  
A216WCB  
Налягане PN 10  
Размер DN-50-150

Specifications	
Bonnet connection:	Bolted
Execution:	Straight
Connection type:	Flanged
Operation:	Handwheel
Actuation:	Multiturn
Trange at Pmax 4 Bars:	-10 °C ÷ +60°C

Dn	Pressure rating	Connection	L	D	H	H1	M	Weight (kg)
50	PN 4	PN 10	137	165	280	200	140	15
65	PN 4	PN 10	148	185	340	240	140	21
80	PN 4	PN 10	174	200	360	260	140	27
100	PN 4	PN 10	195	220	410	300	140	37
125	PN 4	PN 10	216	250	485	350	160	50
150	PN 4	PN 10	242	285	520	400	160	71