

STORM VALVE NODULAR IRON STRAIGHT FLANGED DIN PN 10

Материал nodular iron EN-JS1025; DIN
GGG40.3
Налягане PN 10
Размер DN-50-150

APPLICATIONS

Discharge of sewage water. For vertical installation.

VARIANTS

Other dimensions on request.

MEDIA

Seawater and freshwater

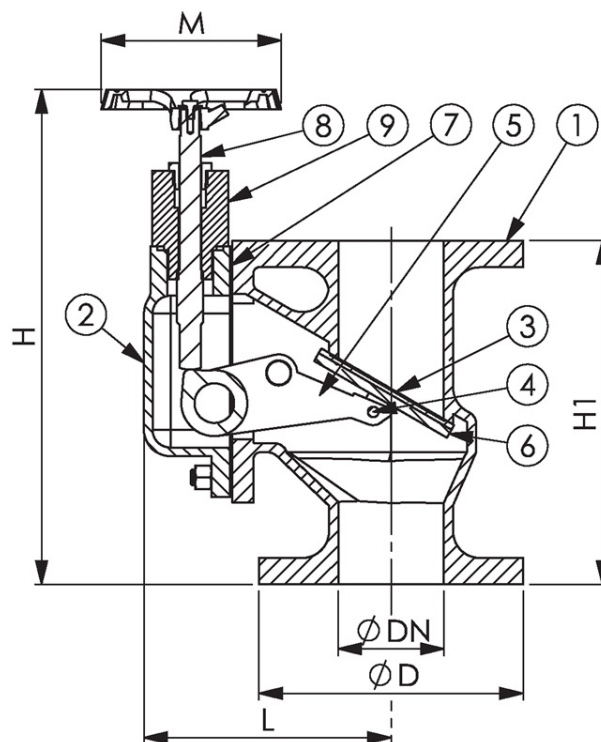

No.	Parts	Material
1	Body	Ductile iron EN-JS1025 (GGG40.3)
2	Bonnet	Ductile iron EN-JS1025 (GGG40.3)
3	Sealing	NBR
4	Pin	Stainless steel 1.4401 (AISI316)
5	Lever	Ductile iron EN-JS1025 (GGG40.3)
6	Disc	Bronze CC491K (RG5)
7	Gasket	NBR
8	Stem	Brass CW614N (Ms58)
9	Stem Nut	Brass CW614N (Ms58)

Specifications

Standart:	DIN
Flange standard:	EN 1092-3
Face to face standard:	EN 558, series 48

STORM VALVE NODULAR IRON STRAIGHT FLANGED DIN PN 10

Материал nodular iron EN-JS1025; DIN
GGG40.3
Налягане PN 10
Размер DN-50-150

Specifications	
Bonnet connection:	Bolted
Execution:	Straight
Connection type:	Flanged
Operation:	Handwheel
Actuation:	Multiturn
Trange at Pmax 4 Bars:	-10 °C ÷ +60 °C

Dn	Pressure rating	Connection	L	D	H	H1	M	Weight (kg)
50	PN 4	PN 10	137	165	280	200	140	15
65	PN 4	PN 10	148	185	340	240	140	21
80	PN 4	PN 10	174	200	360	260	140	27
100	PN 4	PN 10	195	220	410	300	140	37
125	PN 4	PN 10	216	250	485	350	160	50
150	PN 4	PN 10	242	285	520	400	160	71