

THERMODYNAMIC STEAM TRAP WITH AIR RELEASE SCREW ENDS / FLANGED ADCA TH32Y - TH32Y / CK

Материал cast steel 1.0460
 Налягане PN 40
 Размер 1/2" - 1" / DN 15 - 25

TECHNICAL DESCRIPTION

TH thermostatic steam traps series TH32Y with automatic venting. They are specially designed to be mount in industrial equipment such as sterilizers, food processing equipment, laundry equipment and in chemical industry facilities. Connections can be threaded or flanged.

OPERATION

Controlled unloading.
 Drains condensate with near temperature to steam.
 Thermostat for various subcooling (5°K to 30°K).
 Excellent bleeding.
 Work with moderately steam.
 Built-in filter.

WORKING FLUID / MEDIA

Overheated steam

OPTIONS

- LC - low capacity
- Integral non-return valve
- Purge valve.

MODELS

- TH32Y
- TH32Y-CK (non-return valve)

INSTALLATION RECOMMENDATIONS

- Horizontal installation is recommended.
- Can be installed in any position according to the manufacturer's installation and maintenance instructions.

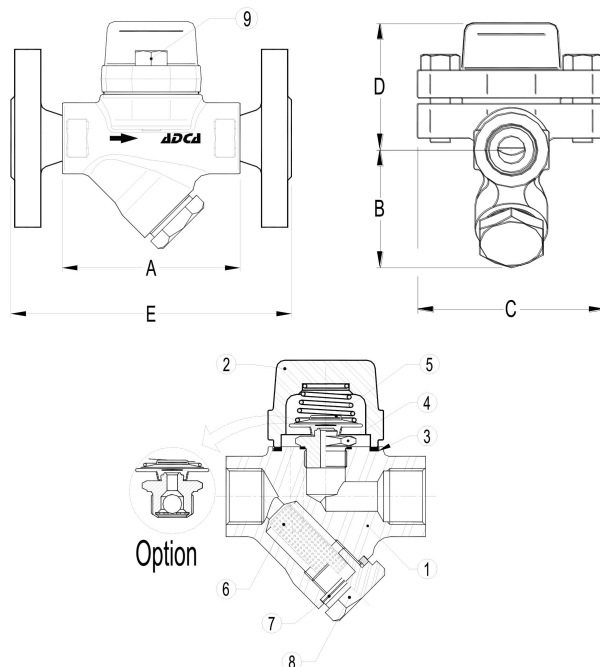

**THERMODYNAMIC STEAM TRAP WITH AIR
RELEASE SCREW ENDS / FLANGED ADCA
TH32Y - TH32Y / CK**

Материал cast steel 1.0460
Налягане PN 40
Размер 1/2" - 1" / DN 15 - 25

No.	Part	Material
1	Body	P250GH / 1.0460
2	Cover	P250GH / 1.0460
3	Gasket	StainlessSt./Graphite
4	Valve Seat	AISI 304 / 1.4301
5	Thermostatic element	St.Steel
6	Strainer screen	AISI 304 / 1.4301
7	Gasket	StainlessSt./Graphite
8	Cover strainer	A105 / 1.0432
9	Bolts	A2-70

Specifications	
Building standards:	DIN
Connection:	Threaded BSP / Flanged
Bonnet connection:	Bolted bonnet
Execution:	Straight
Operation:	Automatic
Air release:	With automatic air release
Mounting:	Preffered horisontal

Max. working pressure (bar) at ?c		
PMO - maximum operating pressure	22	[bar]
Minimum operating pressure	0.25	[bar]
TMO - maximum operating temperature	250	

Body limiting conditions		
FLANGED PN40 / ANSI 300	FLANGED ANSI #150	Related temp
Allow. Press. / Bars	Allow. Press. / Bars	0C
40 bar	19,3 bar	
35 bar	15,8 bar	
30,4 bar	12,2 bar	

**THERMODYNAMIC STEAM TRAP WITH AIR
RELEASE SCREW ENDS / FLANGED ADCA
TH32Y - TH32Y / CK**

Материал cast steel 1.0460
Налягане PN 40
Размер 1/2" - 1" / DN 15 - 25

Body limiting conditions		
27,6 bar	10,2 bar	

Flow rate capacity in kg/h																
MODEL													SIZE DN	DIFFERENTIAL PRESSURE (bar)		
0.2			0.3	0.5	1	1.5	2	3	4	6	8	10	13	15	20	22
TH32Y	15 - 25	70	120	140	255	330	385	455	510	600	670	700	720	750	775	790
TH32YLC	15 - 25	45	55	70	95	125	135	180	200	270	315	330	360	370	405	415

Dimensions (mm)												
Screwed and SW *							EN PN16/PN40		ANSI 150		ANSI 300	
SIZE DN	A	B	C	D	WGT. Kg	E	WGT. Kg	E	WGT. Kg	E	WGT. Kg	
15-1/2"	95	59	95	65	1.6	150	3.2	150	2.7	150	3.5	
20-3/4"	95	59	95	65	1.6	150	3.9	150	3.1	150	4.7	
25-1"	95	65	95	65	1.8	160	4.7	160	4.3	160	5.9	